

INSTALLATION, OPERATING & MAINTENANCE INSTRUCTIONS FOR

Plenty Duplex Filters 1"NB to 4"NB

Celeros Flow Technology
Plenty Filters
Hambridge Road,
Newbury,
Berks.
RG14 5TR
United Kingdom

Tel: +44 (0)1635 42363
Email: plentyfilters@celerosft.com

Website: www.celerosft.com

CONTENTS

Section	Description	Page
1.0	General Safety Instructions	3
2.0	General Description	4
2.1	General Description	4
2.2	Design & Operating Conditions	5
2.3	Filtration Level	5
3.0	Storage & Preservation	6
3.1	Short Term Storage	6
3.2	Storage of Equipment in Unpacked Condition	6
3.3	Protection of installed out-of-service equipment	6
4.0	Installation	7
4.1	Lifting	7
4.2	Installation	7
4.3	Maintenance Area Required	8
4.4	Warning: Isolated Chamber Pressure	8
5.0	Commissioning Procedures	9
5.1	Pre-Commissioning	9
5.2	Commissioning	10
5.3	Warning	10
6.0	Operating Instructions	11
6.1	Putting into Operation	11
6.2	Changeover Valve Operation	11
6.3	Differential Pressures	11
7.0	Maintenance Instructions	12
7.1	Maintenance Schedule	12
7.2	Before Opening the Filter for Maintenance	12
7.3	Opening the Filter Cover	14
7.4	Basket Cleaning, Dismantling and Reassembly	15
7.5	Installation of the Baskets in the Filter	16
7.6	Sealing Grease	18
8.0	Reference Documents	19

Celeros Flow Technology - Power and Energy International Limited

Copyright in the work manifest in this document belongs to Power and Energy International Limited. Supply hereof is subject to restrictions on the use and dissemination of the contents and designs and ideas contained therein or derived therefrom. Infringement of such restrictions or copyright will be actioned to the extent permissible in law.

SECTION 1: General Safety Instructions

Keep these instructions in a readily accessible place.

It is the responsibility of the equipment owner or operator to ensure that any one installing, operating or maintaining the equipment has read and fully understood these instructions and complies with them at all times.

Carry out work on the equipment only when:

- Equipment has been fully isolated from the process line and valves have been locked off and secured against accidental opening.
- Where necessary the equipment has been depressurised.
- Where required the equipment has been suitably flushed and purged of harmful gases, vapours or liquids.
- Any electrical supply has been disconnected and secured against accidental energising either by locks, key switches or removal of supply line fuses.
- A notice has been attached to locked out process valves or electrical switchgear clearly stating that work on equipment is in progress.
- Any lifting equipment or tackle is in good order and certified for intended use.
- The persons carrying out work on the equipment have been provided with suitable tools for the task to be conducted and have the necessary protective clothing and safety equipment, and are suitably trained in their use.

It is the responsibility of the owner / operator to ensure full compliance with all relevant safety and environmental regulations during movement of, installation, operation, maintenance, assembly and disassembly of the equipment. All international, national and local codes of practice shall be observed and shall take precedence over any stated or implied practice in this document.

It is the responsibility of the owner / operator to ensure that the equipment is only used for the duties for which equipment has been supplied, and that all operations are within the design and operating parameters stated on the equipment data sheets and/or general arrangement drawings.

The equipment must be installed, started up, operated and maintained and if necessary repaired only by authorised, properly trained and qualified personnel.

Celeros Flow Technology - Power and Energy International Limited

Note: Power and Energy International Limited have no control over the use or operating conditions and therefore cannot be held responsible for any damage to or caused by the filter, or any subsequent costs incurred. It is essential that the user is satisfied with the suitability of the equipment for the intended application.

SECTION 2: General Description

2.1 General Description

2.1.1 The Plenty Duplex Filter is of simple robust construction, the large filtration area and simplicity of maintenance are prime features of the filter.

The Duplex filter provides two filtration chambers complete with an integral changeover valve in a single body. Flow passes through one chamber or the other, thus enabling the baskets to be removed and cleaned without interruption to the process flow.

The filter generally comprises a pressure containment body with Inlet, Outlet, Vent, Drain and Differential Pressure Instrument connection points. Additional connections may be provided to order. Access to the filter baskets is via a quick release cover which requires no tools for removal. The cover seals with an 'O' Ring which fits into a groove machined in the top of the filter body. Each basket is fitted with a handle for lifting out of the filter body.

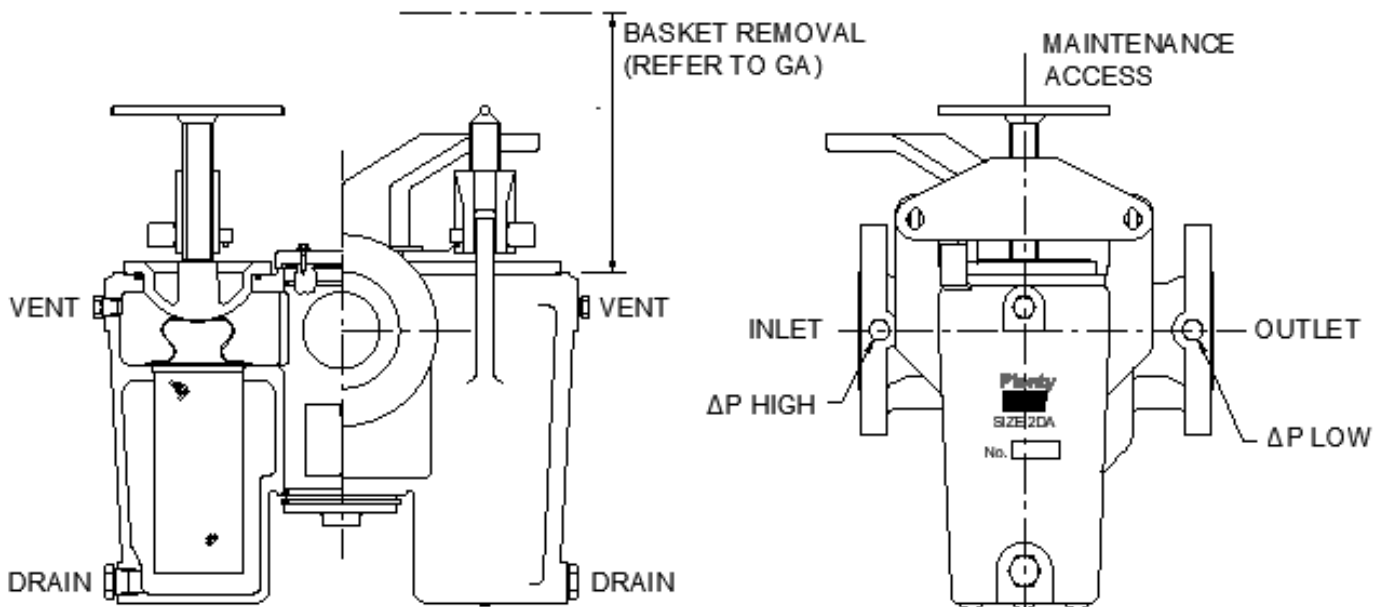

2.1.2 A valve provided on the top of the filter allows the pressure in the two chambers to be equalised before changing over. The changeover valve is lubricated and sealed using grease which must be recharged on a regular basis. Refer to section 7 for details.

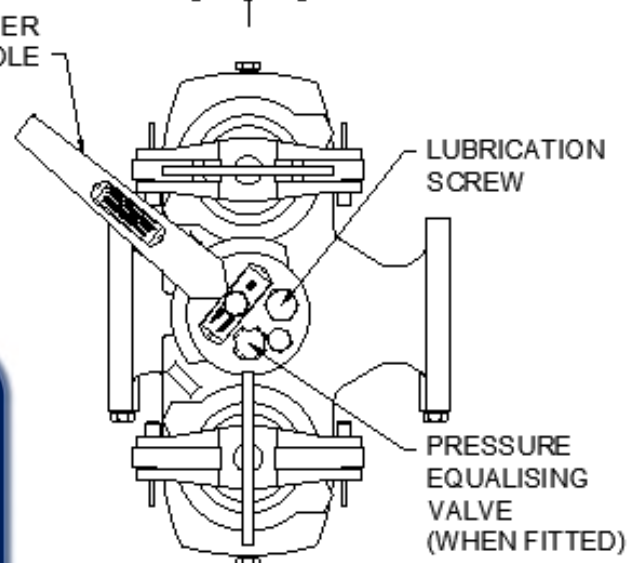

IMPORTANT

All filters are configured to order. The images above are representative of typical filters. The number, type, size and location of connection points will vary with specific order requirements. Refer to the order specific General Arrangement drawings for details.

- 2.1.3 The filter is supplied complete with factory fitted basket type filtration elements sized and designed for operating conditions as indicated on equipment General Arrangement drawings and equipment Data Sheets. The filters are designed to remove solid particulate as stated in the Data Sheet.
- 2.1.4 **Important:** Flow direction is critical to the operation and performance of this product. The filter should be fitted into the line such that flow is from the inside of the basket to the outside. Inlet and Outlet connections are clearly identified on the equipment General Arrangement drawing which shall be used as the ruling document in the case of conflict between these instructions and project drawings.

During installation, operation and maintenance all health and safety, environmental and local site regulations shall be observed.

2.2 Design & Operating Conditions

- 2.2.1 Equipment should only be operated on duties for which the equipment has been supplied and within the operating and design parameters stated on equipment nameplates and General Arrangement drawings. Design and operating conditions are fully detailed on the equipment Data Sheets.
- 2.2.2 The filters are of vertical cast steel construction designed to rest on the cast feet at the bottom of the filter body on a flat prefabricated base plate or plinth. The filter dimensions are as per equipment General Arrangement drawings.

2.3 Filtration Level

- 2.3.1 The filtration level provided at the time of delivery is as stated on the equipment Data Sheets.
- The term "at the time of delivery" is used here as it is perfectly possible for the owner/operator to procure replacement filter baskets from Plenty Filters to fit inside the same housing. Later baskets may be specified with a different filtration rating to those originally supplied should the process and/or performance requirements of the filter have changed.

SECTION 3: Storage & Preservation

3.1 Short term storage

- 3.1.1 The equipment will be prepared and packaged for transportation to site and suitably prepared for medium term storage (6 months from shipment) in a covered warehouse. Connections that do not have permanent blinds will be sealed against ingress of moisture and foreign matter. It is recommended that the filters remain in the original packaging, for ease of storage and protection, until required for use.
- 3.1.2 Upon receipt the equipment should be inspected to ensure all components have been received and are in an acceptable condition. Any deficiency in scope of supply or damage to equipment which may have occurred during transit should be reported in writing to the customer service manager at Plenty Filters, Hambridge Road, Newbury, Berkshire RG14 5TR England. (Tel +44 1635 42363).
- 3.1.3 Where equipment is to be stored for longer periods, Plenty Filters should be consulted to assess the storage environment and advise if additional protective coverings and/or additional preventative maintenance is required. Failure to maintain and suitably protect equipment during storage may effect manufacturers guarantees.
- 3.1.4 Where covered warehousing is not available all items should be suitably covered to prevent deterioration.

3.2 Storage of equipment in unpacked condition

- 3.2.1 If unpacked, the equipment **must** be placed in a dry covered warehouse. The goods can be stored for up to 6 months without the need to take further actions to preserve or protect the equipment. Where storage periods exceed six months the equipment should be periodically inspected (at 2 month intervals) to confirm that no deterioration is evident. If deterioration has occurred the equipment should be cleaned and additional preventative actions taken as necessary to prevent further deterioration. Failure to maintain and suitably protect equipment during storage may effect manufacturers guarantees.

3.3 Protection of installed out of service equipment

Where equipment is installed but is not operational the following precautions and preventative measures shall be taken.

- 3.3.1 New, dry, un-used baskets may be left in situ indefinitely if the remaining procedures below are followed. If the unit has been in service it should be drained of all process fluid or test media, then cleaned and dried. The basket should be removed, cleaned or replaced and re-installed. The cover should be left closed to service condition requirements.
- 3.3.2 All ancillary connections, vents and drains should be closed. Where equipment is installed in areas of high humidity or where there are large variations in ambient temperatures, the equipment drain valves should be periodically opened to drain any condensate which may have accumulated.
- 3.3.3 Before putting back in service a new cover seal should be fitted. The basket should be removed, cleaned or replaced and re-installed. All checks as noted under sections 4 & 5, Installation and Commissioning, should be conducted.

SECTION 4: Installation

4.1 Lifting

- 4.1.1 Equipment and components should be lifted in a safe manor by wrapping appropriately sized slings under the Inlet & Outlet connections on the filter body.
- 4.1.2 The approximate empty weight of the Filter is as stated on the equipment General Arrangement drawing.

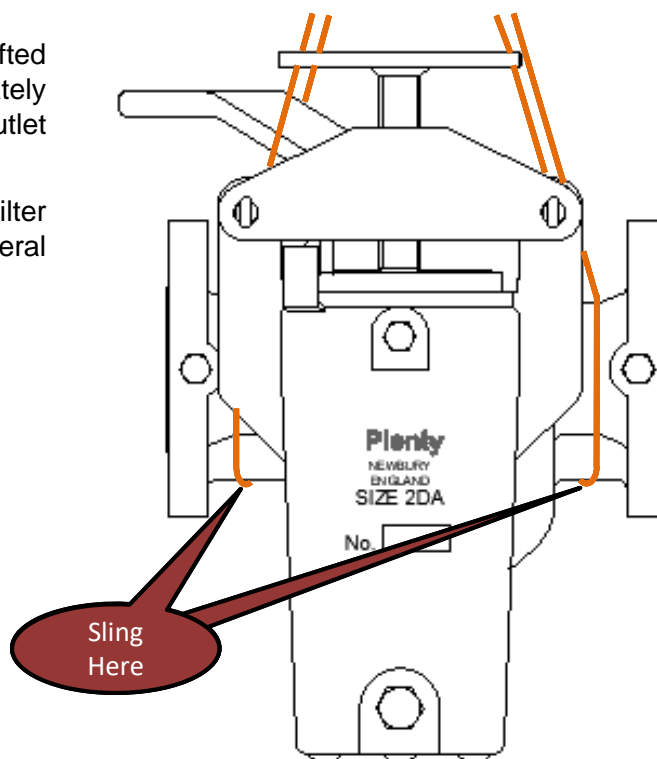

4.2 Installation

- 4.2.1 Prior to installation of this equipment reference should be made to General Arrangement drawing. All temporary covers and protective packaging should be removed.
- 4.2.2 **Important:** Flow direction is critical to the operation and performance of this product. The filter should be fitted into the line such that flow is from the inside of the basket to the outside. Inlet and Outlet connections are clearly identified on the equipment General Arrangement drawing which shall be used as the ruling document in the case of conflict between these instructions and project drawings. All ancillary connections should be made.
- 4.2.3 The product is designed to rest on the cast feet at the bottom of the filter body on a flat prefabricated base plate or plinth.
Due care should be taken to ensure the supporting structure is flat, clean and free of debris in order to minimise distortion or movement of the filter when it is secured.
- 4.2.4 Ensure sufficient space is available to access ancillary connections and associated valves.
- 4.2.5 Due care should be taken to check mating flange alignments before bolt-up to ensure excessive external loading is not imposed on the product due to pipe strain caused by poorly oriented / positioned pipework or flanges. Position gaskets and tighten flanges.
- 4.2.6 Provision must be made for isolating the Filter from the process flow and for draining and venting the Filter body.
- 4.2.7 Recheck all flange connections and tighten to recommended bolt tension for the size and type of flange.
- 4.2.8 Insulation and Fireproofing (by others) should only be installed after all connections have been correctly completed and tested.

4.3 Maintenance Area Required

- 4.3.1 Sufficient clearance must be available above the filter to allow opening of the cover and removal of the internal basket. The clear distance required for basket removal is as stated on the equipment General Arrangement drawing.

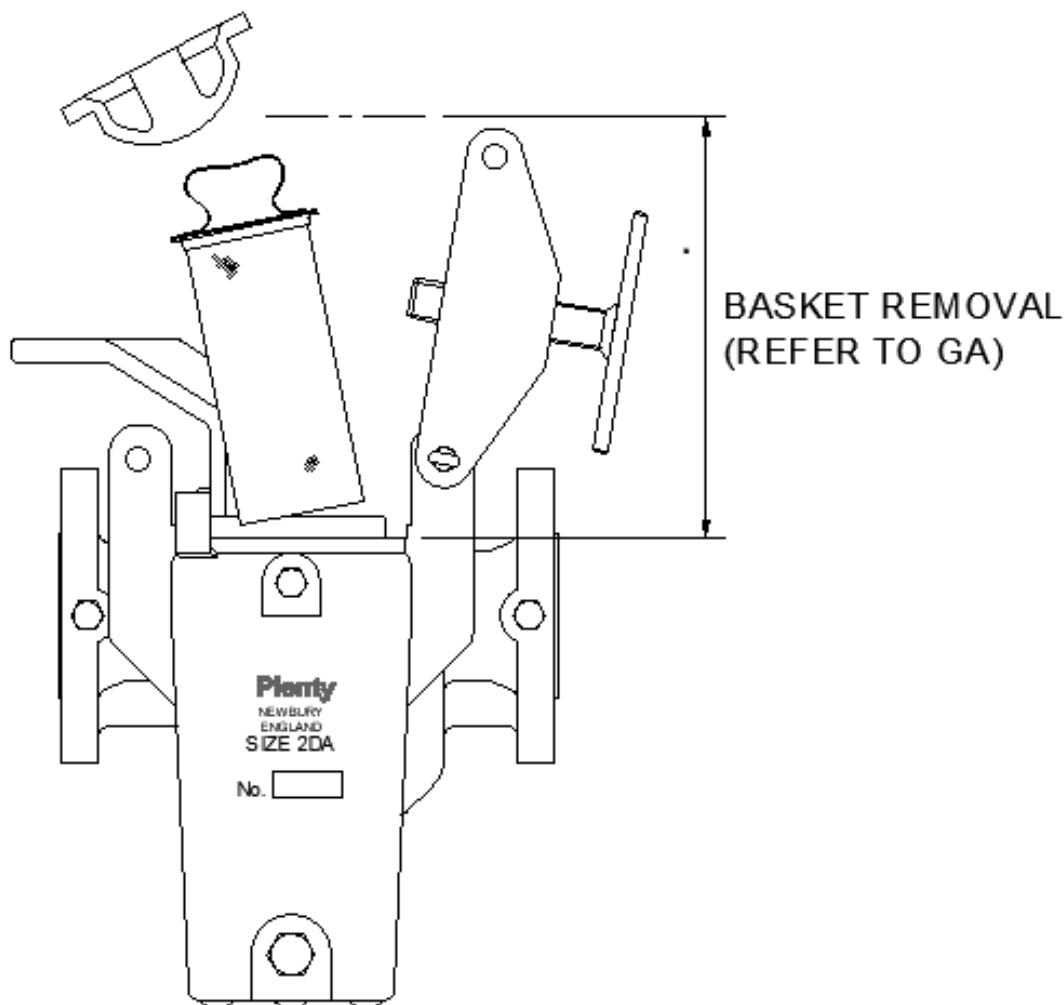

4.4 **Warning:** Isolated Chamber Pressure

- 4.4.1 **IMPORTANT:** The chamber which is isolated and out of use is sealed by the changeover valve. This chamber may be full of process fluid. Any rise in temperature can cause the fluid to expand and result in an increase in the internal pressure. The high pressures generated may cause damage to the filter body.
- Therefore, if the body is fitted with HEATING TAPE or a STEAM JACKET, or if it is possible that the temperature of the process fluid passing through the filter may increase, the PRESSURE EQUALISING VALVE should be left open and only closed when actually opening a chamber for access to the basket (refer to section 7 for details).

SECTION 5: Commissioning Procedures

5.1 Pre-Commissioning

- 5.1.1 Check the Filter has been correctly installed and the associated valves and control equipment (supplied by others) are in the correct position and are operational.
- 5.1.2 Specifically check that the instrumentation system includes provision of a differential pressure gauge, transmitter or switch suitable to measure the operating differential pressure between inlet and outlet sides of the filter.

Warning

**The filter may become unstable during this operation unless secured in the piping arrangement.
Do not attempt to open the cover with the filter unsecured.**

- 5.1.3 Prior to commissioning the covers should be opened. The filter baskets should be checked to ensure correct installation and to ensure the filter is free of any debris which may have entered during installation (see section 7 for detailed instructions).
Close the covers.

- 5.1.4 When commissioning a filter after an extended period of storage the chamber changeover valve lubricant should be refreshed and the valve rotated in each direction as follows to ensure the valve is sealing correctly.

- Check that the chamber Pressure Equalising Valve (where fitted) is open. Unscrew the valve one complete turn.
- Check that the correct sealing grease, compatible with the process fluid, has been selected (refer to the table in section 7.6).
- Recharge the grease by removing the Lubrication Screw and inserting a stick of the appropriate specification grease then replacing the Lubrication Screw and screwing right down.
- Turn the changeover valve over to the opposite chamber. Rotate the handle hard over against the opposite stop.
- Recharge the grease once again by removing the Lubrication Screw and inserting a stick of the appropriate specification grease then replacing the Lubrication Screw and screwing right down.
- Turn the changeover valve again through it's full extent of travel hard over against the opposite stop.
- The chamber Pressure Equalising Valve (where fitted) should remain open for commissioning.

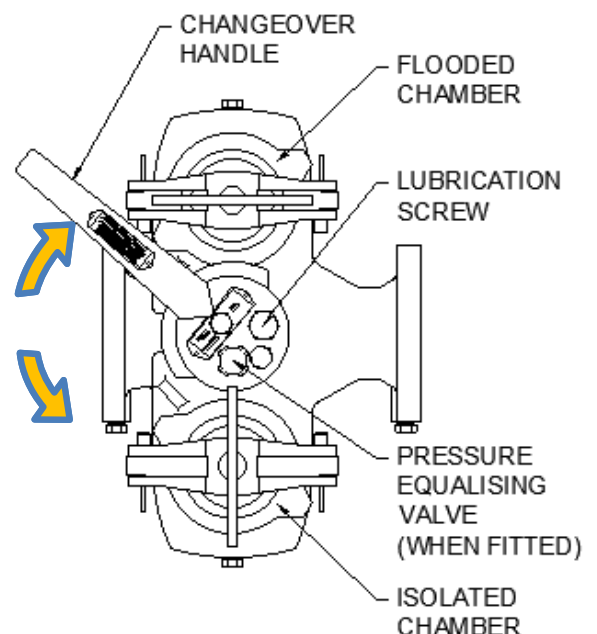

5.2 Commissioning

- 5.2.1 With outlet and drain connections closed, and the vent connection open, slowly open the inlet valve and flood the Filter, expelling any trapped air.
- 5.2.2 When the purging operation has been completed close the vent and gradually open the outlet valve.
- 5.2.3 Fully pressurise the Filter and check all bolted connections for leaks. Make good any leaks if found. The Filter is now ready for operation.

5.3 Warning

- 5.3.1 Warning: Do not proceed to put the unit into operating (fluid flowing) condition until the Operating Instructions in section 6 have been implemented and are fully understood by all operating personnel.
- 5.3.2 **Note:** It is strongly recommended that full flow should be passed through each process line which feeds the filter for a short period before the filter is put into normal service. Once flow has been sequentially passed via each feeding line, the lines should be closed down, suitably isolated or locked off to allow the filter to be opened and inspected for any construction debris which may have entered the filter (refer to the maintenance instructions in section 7 and Appendix A).

SECTION 6: Operating Instructions

6.1 Putting into Operation

- 6.1.1 Before putting into operation ensure all instructions included in this manual under Sections 4 & 5 Installation and Commissioning have been carried out correctly.
- 6.1.2 Periodically check bolted connections for tightness and leaks, make good if necessary.

6.2 Changeover Valve Operation

- 6.2.1 The changeover valve between the two chambers uses grease as it's sealing medium. The grease also acts as a lubricant for the valve.
- 6.2.2 To maintain the integrity of the seal and to prevent the valve from sticking the grease should be recharged and the valve operated over the full extent of it's travel on a regular basis. On water (or similar) duty, this should be carried out every two days. For self lubricating applications (e.g. oil, or other hydrocarbon liquids) once per week should be sufficient. Refer to section 7.2.1 for detailed instructions.

6.3 Differential Pressures

- 6.3.1 The Filter needs very little attention during normal operation. The need to clean/replace the filter basket is indicated by the pressure drop across the filter. The frequency with which this is required is governed by the debris loading. The calculated pressure drop across the filter in the clean condition is stated on the equipment Data Sheets
- 6.3.2 The Differential Pressure (ΔP) should be monitored. The ΔP should not exceed the Dirty ΔP stated on the equipment Data Sheet (Changeout Required). When the ΔP reaches this pressure the basket should be removed and cleaned or replaced with new (see Section 7). Failure to clean/replace the basket when this pressure is reached may also result in loss of downstream pressure and upset desired downstream process conditions.
- 6.3.3 Unless stated otherwise on the equipment data sheets, Plenty Filter Baskets are designed to withstand a Maximum ΔP (burst pressure) of 1.0 bar.

Warning

Failure to clean the basket(s) and/or replace the filter elements when the Maximum ΔP (burst pressure) across the filter has been reached may cause damage to the filtration membrane and result in debris passing into the line downstream of the filter.

- 6.3.4 The cause of any unusual rise in differential pressure should be investigated. The presence of abnormal contaminant in the process stream is the most probable explanation, but other 'upset' conditions could have the same effect. Simply cleaning or replacing the basket may only temporarily resolve the issue and the pressure could rise once more.
- 6.3.5 **Important:** The pressures stated in the equipment Data Sheets refer to the filters and elements as supplied at the time of delivery. The data is only relevant for the design and operating conditions as stated on the filter data sheet and/or general arrangement drawing. Filters and elements which are capable of operating outside standard parameters are designed to order.

SECTION 7: Maintenance Instructions

7.1 Maintenance Schedule

7.1.1 The Filter is designed such that only minimal maintenance is required.

Description	Interval (every)	Remarks
Visual inspection, external and operation of changeover valve	2-7 days	See 7.1.3 below
Inspection of Filter/internals for damage	6-9 Months	Each time Filter is opened
Lubrication of Cover Seal & Spindle	6-9 Months	Each time Filter is opened (see 7.3 & 7.6)

7.1.2 The changeover valve between the two chambers uses grease as it's sealing medium. The grease also acts as a lubricant for the valve.

7.1.3 To maintain the integrity of the seal and to prevent the valve from sticking the grease should be recharged and the valve operated over the full extent of it's travel on a regular basis. On water (or similar) duty, this should be carried out every two days. For self lubricating applications (e.g. oil, or other hydrocarbon liquids) once per week should be sufficient. Refer to section 7.2.1 for detailed instructions.

7.2 Before Opening the Filter for Maintenance

Safe working procedures compliant with all local regulations shall be followed at all times.

7.2.1 Before opening the filter for maintenance it is advisable to refresh the chamber changeover valve lubricant and operate the valve in each direction as follows to ensure the valve is sealing correctly.

- Take note of which chamber is in service. Write this down or mark on the filter with chalk so that the correct chamber will be opened and the correct basket removed for cleaning after following this procedure.
- Check that the chamber Pressure Equalising Valve (where fitted) is open. Unscrew the valve one complete turn.
- Check that the correct sealing grease, compatible with the process fluid, has been selected (refer to the table in section 7.6).

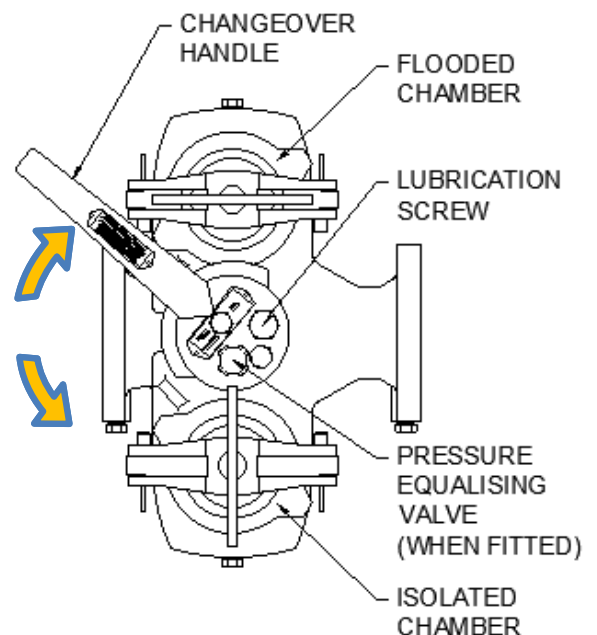

- 7.2.1 Continued...
- Recharge the grease by removing the Lubrication Screw and inserting a stick of the appropriate specification grease then replacing the Lubrication Screw and screwing right down.
 - Turn the changeover valve over to the opposite chamber. Rotate the handle hard over against the opposite stop.
 - Recharge the grease once again by removing the Lubrication Screw and inserting a stick of the appropriate specification grease then replacing the Lubrication Screw and screwing right down.
 - Turn the changeover valve again through it's full extent of travel hard over against the opposite stop.
 - Now that the valve has been operated over it's full extent, move the handle across to close off the chamber to be opened. The protrusion on the changeover handle casting extends above the cover of the chamber which is open to the process flow, preventing this cover from being removed.
- 7.2.2 Close the Pressure Equalising Valve.
- 7.2.3 Slowly open the appropriate filter drain valve to depressurise the isolated chamber. Allow the chamber to slowly depressurise. Follow this by opening the vent valve to assist with fully draining of the filter chamber. Where the equipment vents to atmosphere ensure the vessel has been purged of harmful gases before opening. **CAUTION:** Rapid decompression may cause damage to the elastomer seals fitted to the filter cover and basket. Decompression should be carried out over several hours, not minutes.
- 7.2.4 Purge the vessel of harmful gases, if present, prior to commencing opening. **Only after checking the equipment is fully isolated and evacuated of hazardous / harmful products and or gases should the filter cover be opened to allow access to the internal filter basket.**

Warning

Before opening the filter cover to allow access to the internal basket, it is the responsibility of the owner/operator to ensure that the filter chamber is:

- Fully Isolated.
- Depressurised.
- Evacuated of hazardous / harmful products and / or gasses.

- 7.2.5 **IMPORTANT:** The empty chamber will NOT be positively isolated. The standard acceptance criteria for liquid entering the chamber from the flooded, pressurised side is that the liquid level shall not rise by more than 12mm in a 5 minute period at operating pressure. It is recommended that the drain valve be left open during maintenance to allow this seepage to drain away. Should there be significant leakage past the valve that cannot be resolved by normal charging with grease (per 7.2.1) then the unit may require dismantling for inspection / repair. Contact the factory for further advice.

7.3 Opening the Filter Cover

- 7.3.1 **IMPORTANT:** Inspect the thread on the 'T' Spindle (4) for damage and check that it is generously lubricated. Pay particular attention to the exposed thread immediately beneath the Bridge (3). Releasing the spindle if this thread is dry or damaged or contaminated may result in excessive torque being applied and cause damage to the threaded components. Clean thoroughly and brush the thread with a generous application of grease. Use a good general purpose grease such as Castrol Spheerol LMM or BP Energrease Universal.

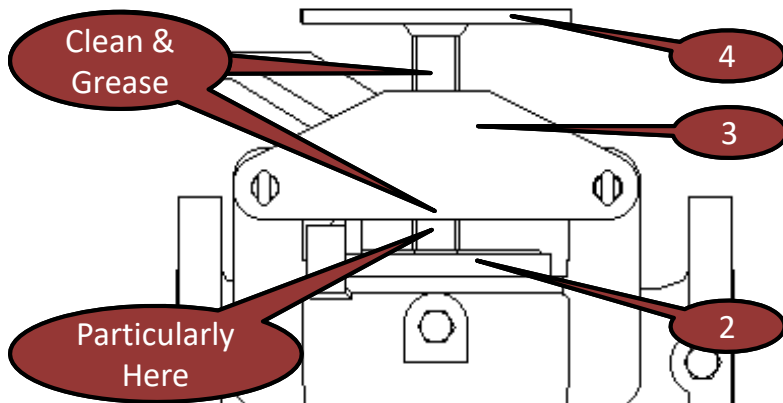

Warning

The filter may become unstable during the following operation unless secured in the piping arrangement. Do not attempt to open the cover with the filter unsecured.

- 7.3.2 Turn the 'T' Spindle (4) in the Bridge (3) counter clockwise to release the load on the filter Cover (2).
- 7.3.3 Slacken the 'T' spindle sufficiently to allow removal of one Drop Nose Bolt (5). The Bridge (3) can now be hinged back to clear the cover completely.

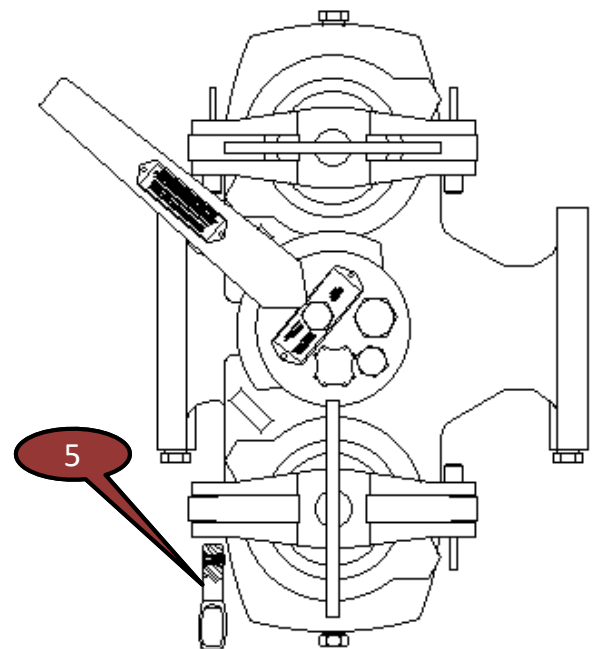
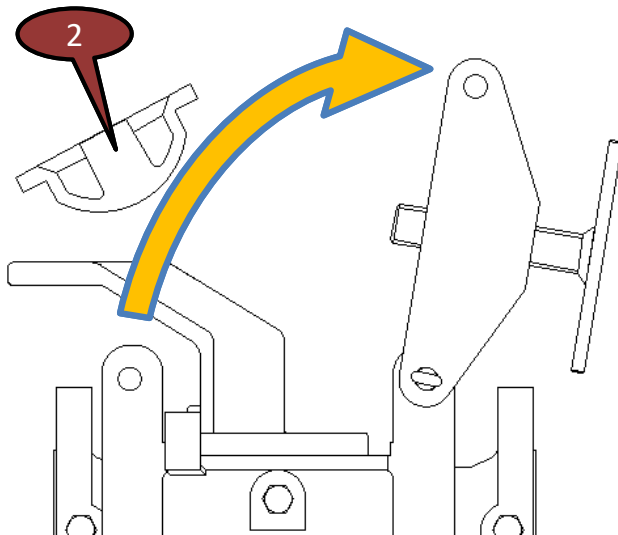

- 7.3.4 Lift the Cover (2) off the body. The flat end of the Drop Nose Bolt can be used to assist cover release by levering under the lug on the side of the cover.
- 7.3.5 Using the built-in handle on the top of the Basket, lift it out of the body.
- 7.3.6 Place a clean rag or other material over the opening in the filter to prevent any ingress of dirt whilst it is open.

7.4 Basket Cleaning, Dismantling and Reassembly

7.4.1 Once removed from the filter the basket can be cleaned using a medium pressure water jet, compressed air, or by submergence in a liquid bath. Care should be used to prevent damage to the basket during cleaning. Once cleaned, carefully examine the basket and mesh for fractures, tears or other damage. Replace any suspect items with new.

7.4.2 **Important:** A fine mesh insert has been used to line the inside of the perforated basket, great care should be taken to prevent damage to this mesh when removing contaminants. Under no circumstances should sharp or metallic scrapers of any kind be used to remove debris from the mesh.

Pressurised water/steam cleaning must not be used on the clean side of the basket to wash away debris on the dirty side. This could cause damage to the mesh.

7.4.3 The mesh Insert (12) may be removed by dismantling the basket assembly.

7.4.4 Remove the M6 Nuts (4pcs) which retain the basket Handle.

7.4.5 The Handle and the mesh Insert can now be removed from the main perforated Basket.

7.4.6 Each component can now be cleaned separately. However, dependent on the nature of the contaminant, it may be more viable to fit a new insert rather than attempting to clean the existing one. Fine mesh inserts are very delicate. Attempting to remove contaminant other than by gentle washing is very likely to cause damage.

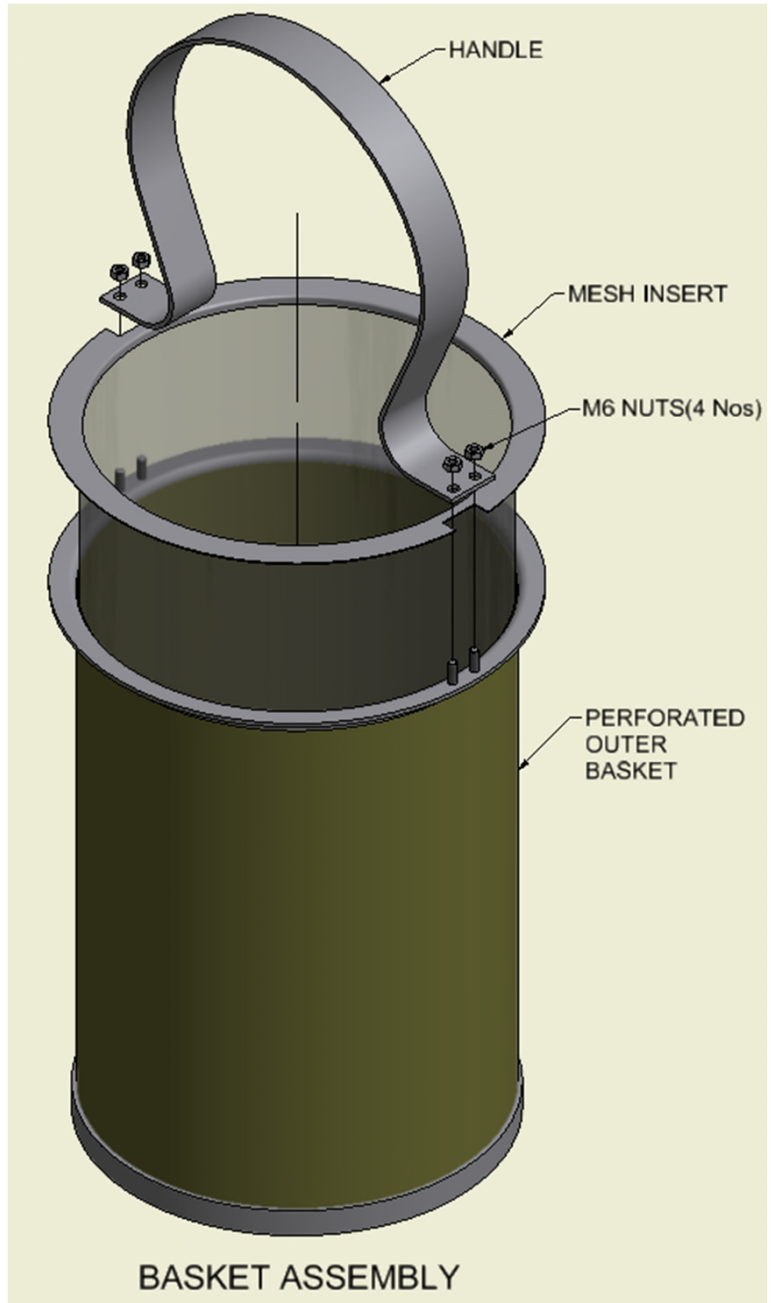

7.4.7 Once cleaned, carefully examine the basket and mesh for fractures, tears or other damage. Replace any suspect items with new.

7.4.8 Where fitted (refer to GA Drawing), install a new O-Ring Seal under the top flange of the basket.

7.4.9 To re-assemble the basket, upturn the mesh insert and place it, with the rim downwards, on a clean flat surface.

- 7.4.9 To re-assemble the basket, upturn the mesh insert and place it, with the rim downwards, on a clean flat surface.
- 7.4.10 Carefully lower the basket down over the mesh insert keeping the walls of the basket vertical and ensuring that the handle slots in the insert rim are aligned with the handle fastening pins on the basket. The larger the basket and mesh the greater the care needed.
- 7.4.11 When the basket has been lowered completely over the insert, lift the assembly and rotate so that the handle fixing pins are upwards.
- 7.4.12 Gently "bounce" the basket and mesh on a flat surface so that the insert rim settles down over the basket rim. **DO NOT ATTEMPT TO PUSH THE INSERT DOWN INTO THE BASKET WITH ANY IMPLEMENT WHICH COULD CAUSE DAMAGE TO THE MESH.**
- 7.4.13 The insert should be a "baggy" fit inside the basket. It is purposely designed this way so that it does not become taught, and possibly tear, in service.
- 7.4.14 Assemble the handle onto the studs and refit and tighten the M6 nuts.

7.5 Installation of the Baskets in the Filter

- 7.5.1 Before inserting the clean baskets into the filter, check that sealing locations in the Basket Seat inside the filter are clean and free from contaminants / debris.
- 7.5.2 Lower the basket into the filter body and check that it is seated centrally on the basket seat.
- 7.5.3 Examine the Cover O-Ring recess in the top of the filter. Thoroughly clean the recess, lightly smear with grease**, then place a new O-Ring in position.
- 7.5.4 **IMPORTANT:** Inspect the thread on the 'T' Spindle (4) for damage and check that it is generously lubricated. Tightening the spindle if this thread is dry or damaged or contaminated may result in excessive torque being applied and cause damage to the threaded components. If considered necessary, it may be advisable to remove the spindle from the bridge completely for cleaning and lubricating. Clean thoroughly and brush the thread with a generous application of grease**.
- 7.5.5 Examine O-Ring mating surface on the underside of the filter cover (2) and ensure that it is perfectly clean, lightly smear the area with grease** and lower the cover onto the filter body.

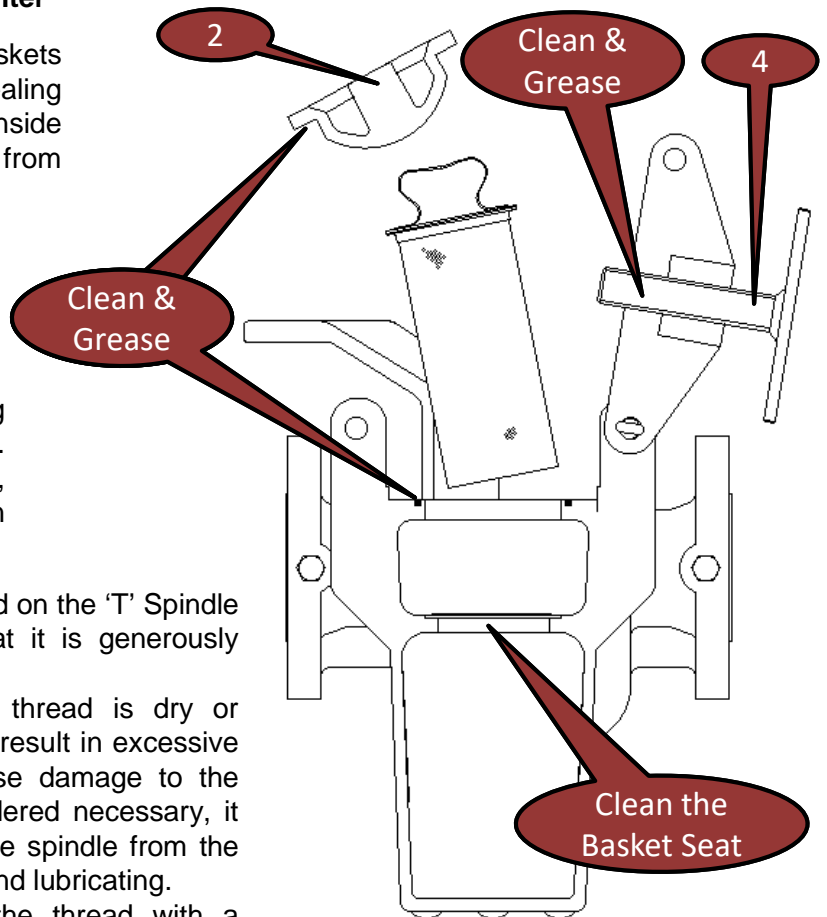

** Use a good general purpose grease such as Castrol Spheerol LMM or BP Energrease Universal.

- 7.5.6 Gently lower the Cover (2) into place at the top of the filter and swing the Bridge (3) back into position. Smear the Drop Nose Bolt (5) with grease and re-install it through the bridge and lug.

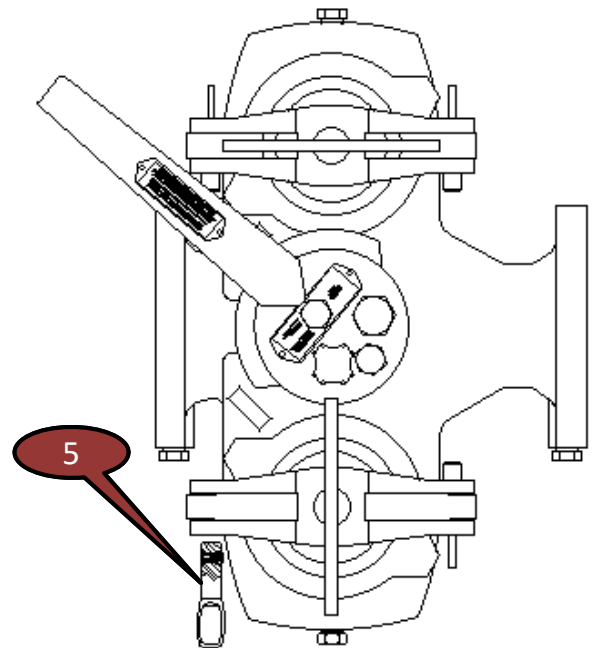
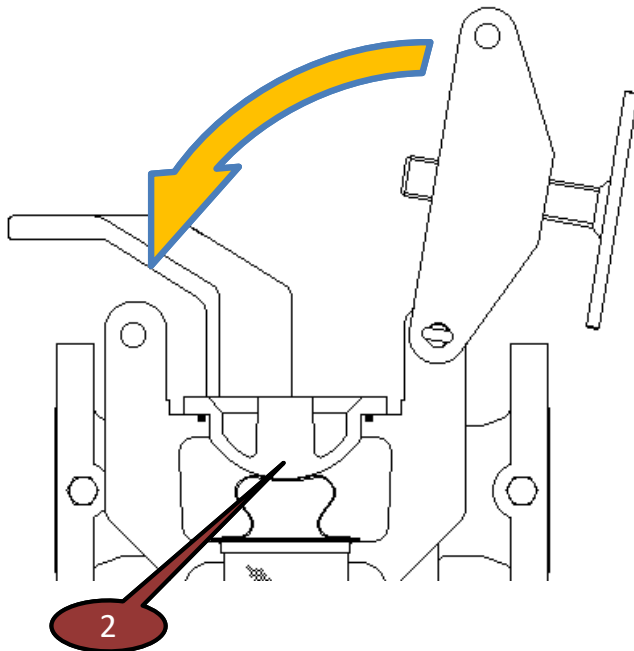

- 7.5.8 Tighten the 'T' Spindle (4) by turning clockwise. The spindle should be tightened by hand only. Tommy bars or extension pipes should not to be used.

- 7.5.9 Return the filter to service by following the instructions included in this manual under Sections 4 & 5 Installation and Commissioning.

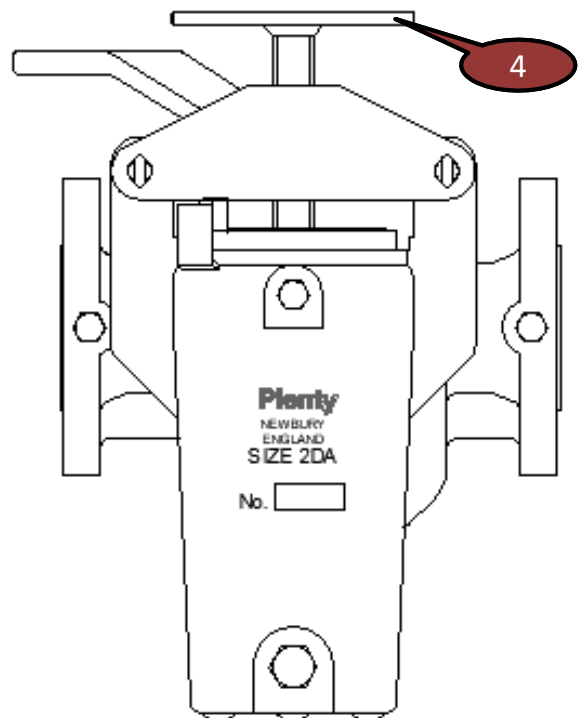

7.6 Sealing Grease

- 7.6.1 Plenty Duplex Filters utilise grease as the sealing media for the changeover valve. The grease specification is dependant on the application and should be chemically compatible and operate within the temperature limits specified.
The end user should satisfy themselves that the grease installed is suitable for the intended application.

Sealant	Temp. Range °C		Recommended for use on:	Not to be used for:
	Min.	Max.		
731	-15	230	Most chemical plant services, water, aqueous solutions, dilute acids, alkaline solutions, compressed air, tars and bitumen.	Strong acid solutions, Petroleum products.
733	0	250	Most hydrocarbons, butane, propane, gasoline, kerosene, oils, fuel oils, natural gas, manufactured gas (including gas with carbon dioxide, hydrogen sulphide, water and condensate), LPG, glycols.	Strong alkaline solutions, High aromatic solvents

- 7.6.2 For applications that fall outside these parameters, contact the factory for further advice.
- 7.6.3 **Warning:** Using types of grease other than those supplied by Plenty Filters may result in failure of the sealing system and loss of the integrity of the pressure containment.

SECTION 8: Reference Documents

- 8.1 The following order specific documents supplement the information included in this manual and should be available for reference alongside.

General Arrangement Drawing

Equipment Data Sheet

Nameplate Drawing